

# retention system

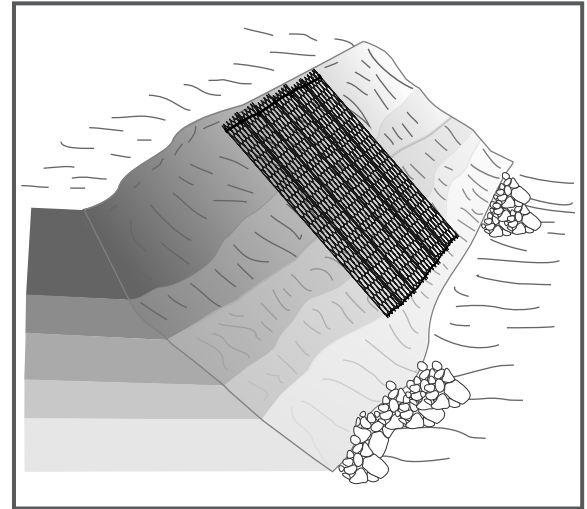

## Hexagonal Mesh - Data Sheet



### Area of Application:

TRUMER rolled hexagonal (double twisted) mesh products are developed for standard strength applications. The mesh can be used for both stabilizing slopes as well as installed as a drape to control erosion. In civil engineering, these rolled meshes have been used for decades to mitigate unstable slopes all over the world.

### Material:

TRUMER rolled mesh products consist of galvanized or galvanized with PVC coated double twisted hexagonal woven mesh wire. They are manufactured in accordance with the European Standard EN 10223-3.

### Installation:

The light weight, long rolls make them ideal for covering large areas of slopes that are affected by unravelling and other mass wasting processes. They are unrolled from the top to the bottom in the hazard zones. The different mesh layers are then connected by overlapping and clipping them together with high-tensile steel ring fasteners.

### Advantages:

Under most conditions, the rolled hexagonal mesh can be easily and quickly installed, thereby considerably reducing costs. Furthermore, corrosion protection is assured by a high-quality of metallic or PVC coating that increases the life and durability of the mesh.

### Anchor Head/Plate\*

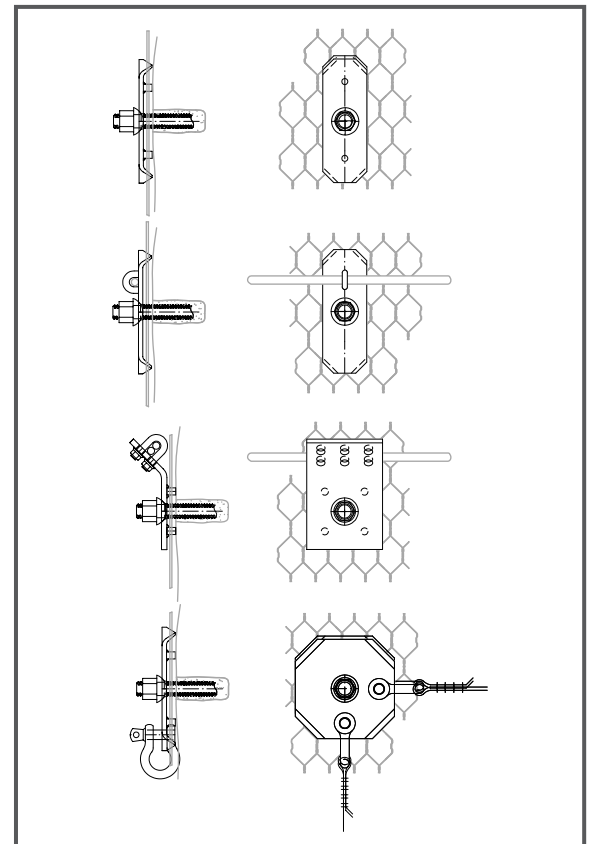

\* Anchor plates with two rope connections, i.e. in vertical and horizontal directions are also available

## Mesh Characteristic mm (in.)

### Coating Type

Mesh Type	Zn/Zn-Al Coated		Zn-Al + PVC Coated	
	Mesh Type	8x10 [+/- 10 %]		8x10 [+/- 10 %]
Nominal Mesh Size <i>D</i>	80 (3.15) [+/- 10 %]		80 (3.15) [+/- 10 %]	
Mesh Wire Diameter	2.7 (0.106)	3.05 (0.12)	2.7 (0.106)	3.05 (0.12)
Selvedge Wire Diameter	3.4 (0.134)	3.9 (0.154)	3.4 (0.134)	3.9 (0.154)
PVC Thickness	N/A		0.5 (0.02)	
Ring Diameter	3.0 (0.118)		3.0 (0.118)	

## Wire Properties

### Wire Diameter mm (in.)

	2.7 (0.106)	3.05 (0.12)	3.4 (0.134)	3.9 (0.154)
	Tensile Strength* <i>N/mm<sup>2</sup> (ksi)</i>	350 to 550 (50.7 to 79.8)		
Elongation* %	> 10			
min. Mass of Coating** <i>g/m<sup>2</sup> (oz/ft<sup>2</sup>)</i>	245 (0.80)	255 (0.84)	265 (0.87)	275 (0.90)
Tolerance*** <i>mm (in.)</i>	[+/-]0.06 (0.0024)		[+/-]0.07 (0.0028)	
Tolerance PVC Thickness *** <i>mm (in.)</i>	[+/-]0.1 (0.0039)			

\* in accordance with European Standard EN 10223-3

\*\* in accordance with European Standard EN 10244-2, class A

\*\*\* in accordance with European Standard EN 10218-2

## Roll Sizing Options

Width <i>W</i> <i>m (ft)</i>	Length <i>L</i> <i>m (ft)</i>	Weight <i>kg/m<sup>2</sup> (lb/ft<sup>2</sup>)</i>	Mesh Wire Diameter Zn/Zn-Al Coated <i>mm (in.)</i>	Mesh Wire Diameter Zn-Al + PVC Coated <i>mm (in.)</i>
2.9 (9.51)	30.0 (98.43)	~ 1.75 (~ 0.36)	2.7;3.05 (0.106;0.12)	3.7;4.05 (0.146;0.159)

Other dimensions are possible in accordance with project specific design requirements

## Mesh Strength Properties

### Wire Diameter mm (in.)

Test Description	2.7 (0.106)	3.05 (0.12)
Tensile Strength, lengthwise <i>kN/m (lb/ft)</i>	52.4 (3,591)	62.2 (4,262)
Tensile Strength, crosswise <i>kN/m (lb/ft)</i>	26.5 (1,816)	28.6 (1,960)
Resistance of Puncture, unsupported* <i>kN (lb/ft)</i>	n/a	32.2 (7,239)

\* tested in open air



## Panel Dimensions

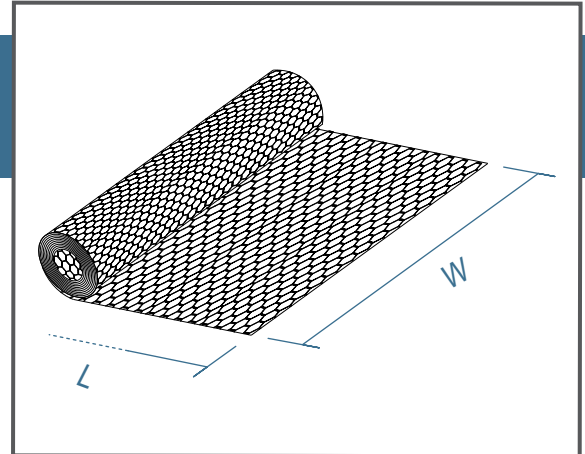

## Mesh Dimensions

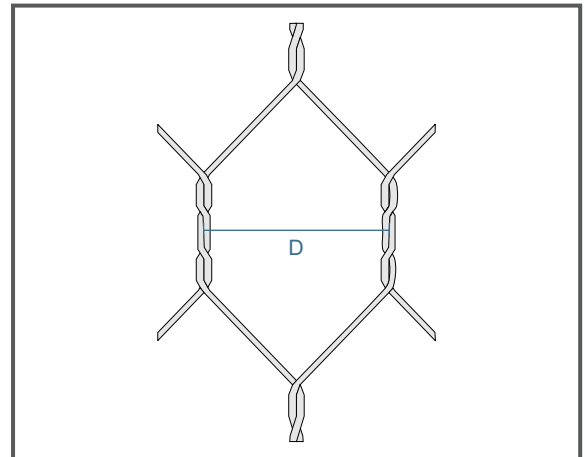

## Seam Connection\*

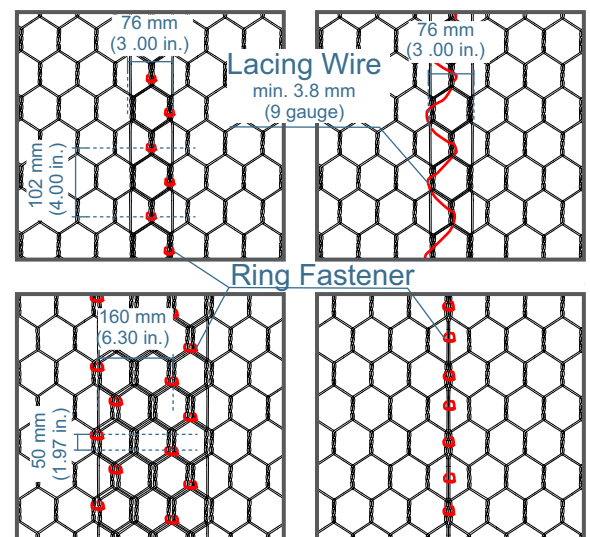

\* Connection details according to state of the art practice. Actual seam connection to be determined by a qualified engineer in accordance with local regulations.